

885N IT

Organization:

To examine:

Approval:

Version: A-01

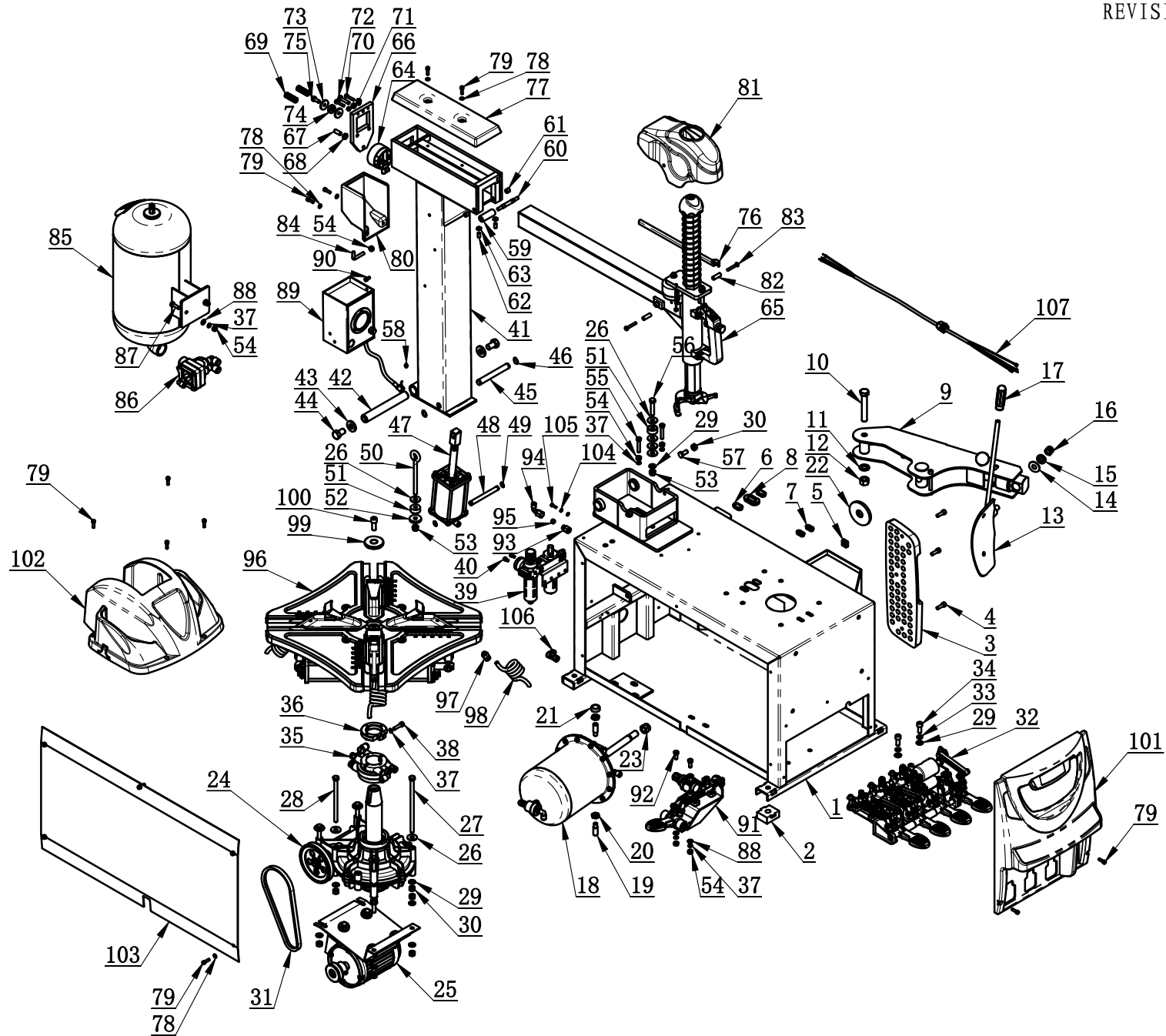

ITEM	PART. No	DESCRIPTION.	QT. Y
1	C-78-1100000	THE BODY WELDING	1
2	C-54-1000005	RUBBER FOOT	4
3	C-5E-1000003	RIM SUPPORT	1
4	GB70. 1-M8×25	INNER HEXA CYLINDRICAL SCREW	3
5	C-54-1000015	STOP-UP	1
6	C-54-1000022	PLUG C	2
7	C-54-1000023	PLUG A	2
8	C-54-1000028	PLUG B	1
9	CT-B-A000000	BEAD BREAKER	1
10	GB5782-M16×100	HEXANGULAR BOLT	1
11	GB95-16	FLAT WASHER	1
12	GB41-M16	HEXANGULAR NUT	1
13	CT-C-2100000	BEAD BREAKER BLADE	1
14	C-54-1000002	WASHER	1
15	GB955-14	WAVE-FORM SPRING WASHER	1
16	GB889. 1-M14	1-TYPE PREVAILING TORQUE TYPE HEXAGON LOCK NUT	1
17	TC-40-1200022	RUBBER COVER	1
18	CT-LS-9200000	BEAD BREAKER CYLINDER ASSEMBLY	1
19	C-54-1000010	SCREWS M14X42	2
20	GB6172. 1-M14	HEXANGULAR THIN NUT	2
21	C-54-1000013	SEALED COVER	1
22	C-54-1000016	WASHER	1
23	GB889. 2-M18×1.5	NUT M18X1.5	1
24	CT-J-4100000	GEARBOX ASSEMBLY	1
25	CT-DJ-0334122	MOTOR	1
26	GB96. 2-10	large washer C grade	11
27	GB5782-M10×200-W8.8	HEXANGULAR BOLT	4
28	GB5782-M10×160-W8.8	HEXANGULAR BOLT	2
29	GB95-10	FLAT WASHER	17
30	GB41-M10	HEXANGULAR NUT	16
31	CT-DJ-0000007	TRIANGLE	1
32	CT-D-6400000	PEDAL ASSEMBLY	1
33	GB93-10	STANDARD SPRING WASHER	2
34	GB70. 1-M10×25	INNER HEXA CYLINDRICAL SCREW	2
35	CT-Q-A100000	ROTATING UNION	1
36	CT-Q-6000000	CLAMP RING	1
37	GB93-8	STANDARD SPRING WASHER	7
38	GB70. 1-M8×30	INNER HEXA CYLINDRICAL SCREW	1
39	CT-F-2121200	AIR REGULATOR ASSEMBLY	1
40	GB70. 1-M6×10	INNER HEXA CYLINDRICAL SCREW	2

ITEM	PART. No	DESCRIPTION.	QT. Y
41	C-77-1200000	COLUMN WELDING ASSY	1
42	C-71-1000012	ROTATION SHAFT	1
43	C-71-1000010	WASHER	2
44	GB5782-M16×25-W8. 8	HEXANGULAR BOLT	2
45	C-71-1000007	PULL-OUT SHAFT	1
46	GB894. 1-16	SHAFT ELATIC BIG RETAINING RING A-TYPE	2
47	CT-XD-4000000	PULL-OUT CYLINDER D80X80	1
48	C-71-1000006	PIN SHAFT	1
49	GB894. 1-12	SHAFT ELATIC BIG RETAINING RING A-TYPE	2
50	C-71-1000008	CONNECTION ROD	1
51	C-71-1000013	WASHER Φ 30xΦ 10x15	2
52	C-71-1000028	WASHER	1
53	GB889. 1-M10	1-TYPE PREVAILING TORQUE TYPE HEXAGON LOCK NUT	2
54	GB41-M8	HEXANGULAR NUT	8
55	GB5782-M8×45	HEXANGULAR BOLT	2
56	GB5782-M10×50	HEXANGULAR BOLT	1
57	C-71-1000009	BOLT	2
58	TC-10-8400006	OIL CUP M6	1
59	C-77-1000001	ROTATING SPACER	1
60	C-77-1000002	SUPPORT SHAFT	1
61	GB77-M12×12	INNER HEXA FLAT TERMINUS SET SCREW	2
62	GB77-M8×16	INNER HEXA FLAT TERMINUS SET SCREW	2
63	GB6172. 1-M8	HEXANGULAR THIN NUT	2
64	C-77-1500000	LOCKING CYLINDER ASSY	1
65	C-6A-1100000	PUSH AND PULL ARM COMPONENTS	1
66	C-77-1400000	QUADRIC LOCK PLATE WELDING	1
67	C-71-1000029	INNER HEXA FLAT TERMINUS SET SCREW	1
68	GB6173-M10×1. 0	HEXA THIN NUT	1
69	C-71-1000018	PRESS SPRING	2
70	GB5782-M6×30	HEXANGULAR BOLT	2
71	GB41-M6	HEXANGULAR NUT	2
72	GB5781-M8×35	HEXANGULAR BOLT	1
73	C-77-1000003	CUSHION	2
74	C-77-1000004	RUBBER WASHER	1
75	GB5783-M8×20	HEXANGULAR BOLT	1
76	C-77-1000009	AIR HOSE CHUTE	1
77	C-77-1000007	PROTECTIVE COVER	1
78	GB95-6	FLAT WASHER	9
79	GB70. 1-M6×20	INNER HEXA CYLINDRICAL SCREW	15
80	C-77-1000008	PROTECTIVE COVER	1

ITEM	PART. No	DESCRIPTION.	QT. Y
81	C-8E-1000002	PROTECTION COVER	1
82	C-77-1000006	PROTECTIVE HOOD LOCK BUSHING	2
83	GB818-M6×40-H	CROSS PANHEAD SCREW	2
84	C-71-1000024	INFLATING GUN HOOK	1
85	CT-K-4100000	STORAGE TANKS ASSEMBLY	1
86	CT-K-2200000	QUICK EXHAUST VALVE ASSEMBLY	1
87	GB5783-M8×25	HEXANGULAR BOLT	2
88	GB95-8	FLAT WASHER	4
89	CT-K-3200000	INFLATOR COVER ASSEMBLY	1
90	GB70. 1-M6×12	INNER HEXA CYLINDRICAL SCREW	2
91	CT-K-1A00000	QUICK INFLATION PEDAL ASSY	1
92	GB5782-M8×20	HEXANGULAR BOLT	2
93	FPC 8-02	MALE STRAIGHT	1
94	FPLF 8-02	FEMALE ELBOW	1
95	C-54-1000027	JOINT SEALING GASKET	1
96	CT-Y-2A00000	TURNTABLE ASSEMBLY	1
97	FPC 10-01	MALE STRAIGHT	4
98	C-54-1000029	PU SPIRAL TUBE	4
99	C-54-1000012	PRESS COVER	1
100	GB70. 1-M12×30	INNER HEXA CYLINDRICAL SCREW	1
101	C-5E-1000002	FRONT COVER	1
102	C-6A-1000001	TOOL BOX	1
103	C-71-1000026	SIDE PANEL	1
104	GB95-5	FLAT WASHER	2
105	GB5782-M5×16-8. 8	HEXANGULAR BOLT	1
106	FPT 6-8-8	DIFFERENT DIA OF UNION TEE	1
107	CT-E-UN00410	CABLE	1

REVISION 15A-01

C-6A-1100000

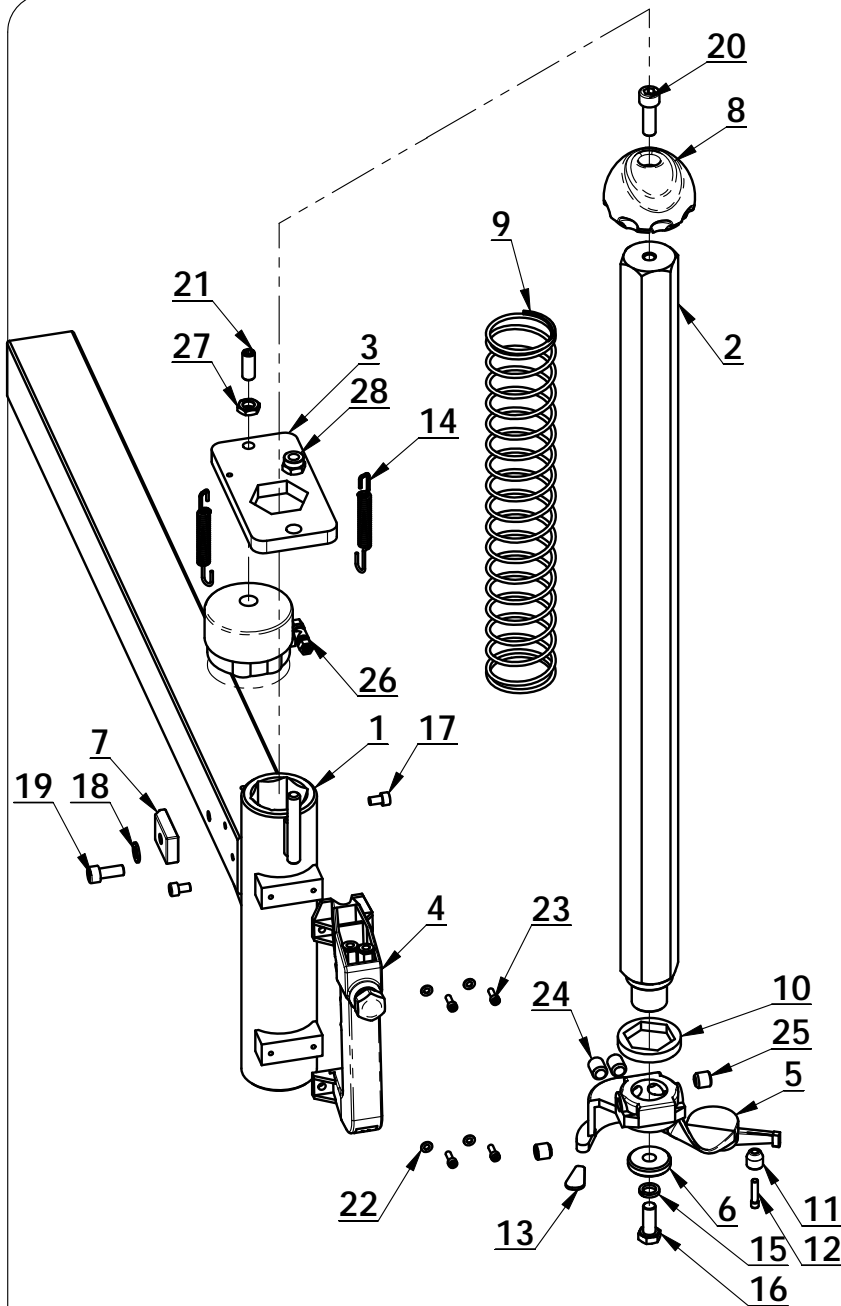

ITEM	PART. No	DESCRIPTION.	QT. Y
1	C-77-1310000	HORIZONTAL ARM WELDING	1
2	C-77-1300003	HEXANGULAR SHAFT	1
3	C-77-1300004	HEXANGULAR LOCK PLATE	1
4	C-71-1330000	HANDLE CONTROLING VALVE	1
5	C-54-1300004	DEMOUNTING HEAD	1
6	C-54-1300008	PRESS WASHER	1
7	C-71-1300005	POSITIONING BLOCK	1
8	C-5E-1300001	VERTICAL SHAFT COVER	1
9	C-54-1300010	VERTICAL SHAFT SPRING	1
10	C-54-1300007	SHOCK ABSORBER WASHER	1
11	C-54-1300009	ROLLER	1
12	C-54-1300006	ROLLER BOLT	1
13	C-54-8000007	PLASTIC COVER	1
14	C-71-1300004	SPRING	2
15	GB93-10	STANDARD SPRING WASHER	1
16	GB5783-M10×25-W8.8	HEXANGULAR BOLT	1
17	GB70.1-M6×10	INNER HEXA CYLINDRICAL SCREW	2
18	GB95-8	FLAT WASHER	1
19	GB70.1-M8×20	INNER HEXA CYLINDRICAL SCREW	1
20	GB70.1-M10×30	INNER HEXA CYLINDRICAL SCREW	1
21	C-71-1000029	INNER HEXA FLAT TERMINUS SET SCREW	1
22	GB95-4	FLAT WASHER	4
23	GB70.1-M4×12	INNER HEXA CYLINDRICAL SCREW	4
24	GB77-M12×16	INNER HEXA FLAT TERMINUS SET SCREW	2
25	GB77-M12×12	INNER HEXA FLAT TERMINUS SET SCREW	2
26	C-71-1320000	LOCKING CYLINDER ASSY	1
27	GB6173-M10×1.0	HEXA THIN NUT	1
28	GB889.1-M10	1-TYPE PREVAILING TORQUE TYPE HEXAGON LOCK NUT	1

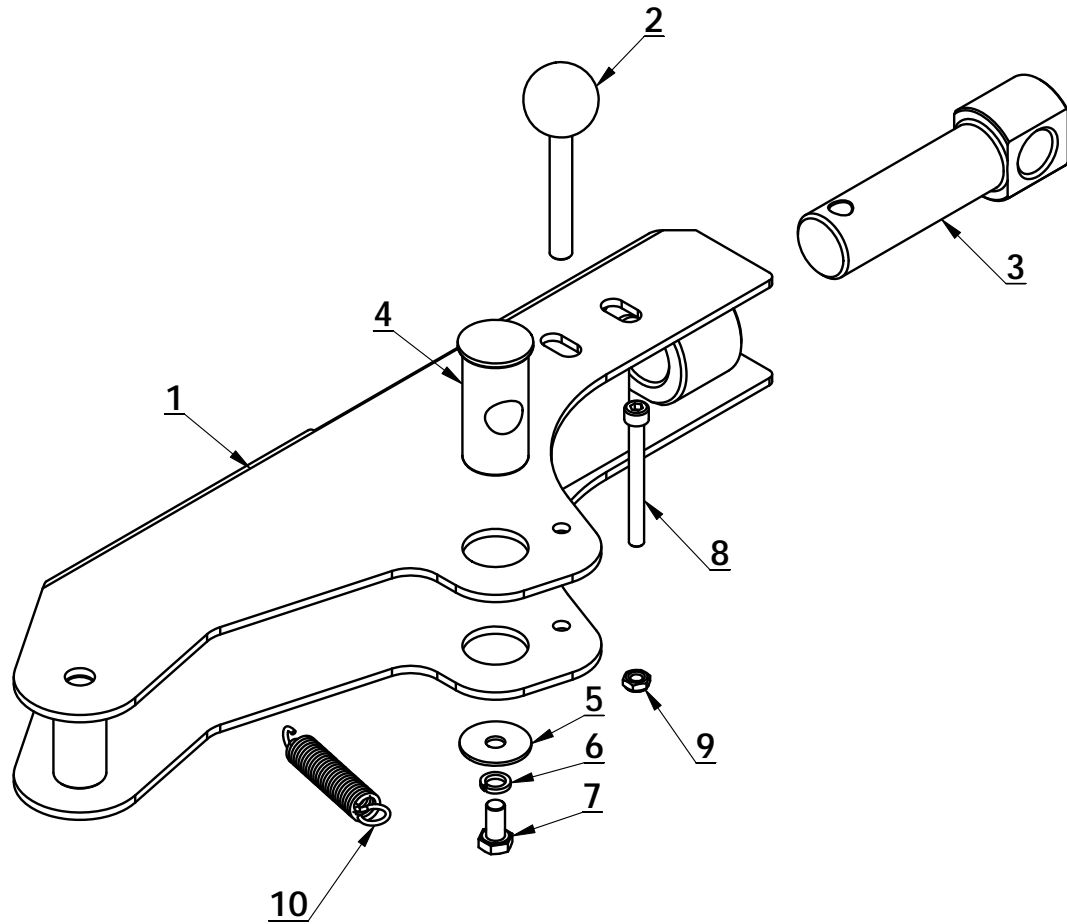

ITEM	PART. No	DESCRIPTION.	QT. Y
1	CT-B-A100000	BEAD BREAKER	1
2	CT-B-A200000	PIN SHAFT	1
3	CT-B-A000001	TURN ROD	1
4	CT-B-A000002	CONNECT ROD	1
5	CT-B-6000003	PAD	1
6	GB93-10	STANDARD SPRING WASHER	1
7	GB5781-M10 × 20	HEXANGULAR BOLT	1
8	GB70. 1-M8 × 80	INNER HEXA CYLINDRICAL SCREW	1
9	GB889. 1-M8	1-TYPE PREVAILING TORQUE TYPE HEXAGON LOCK NUT	1
10	CT-B-2000002	SPRING	1

REVISION 15A-01

CT-D-6400000

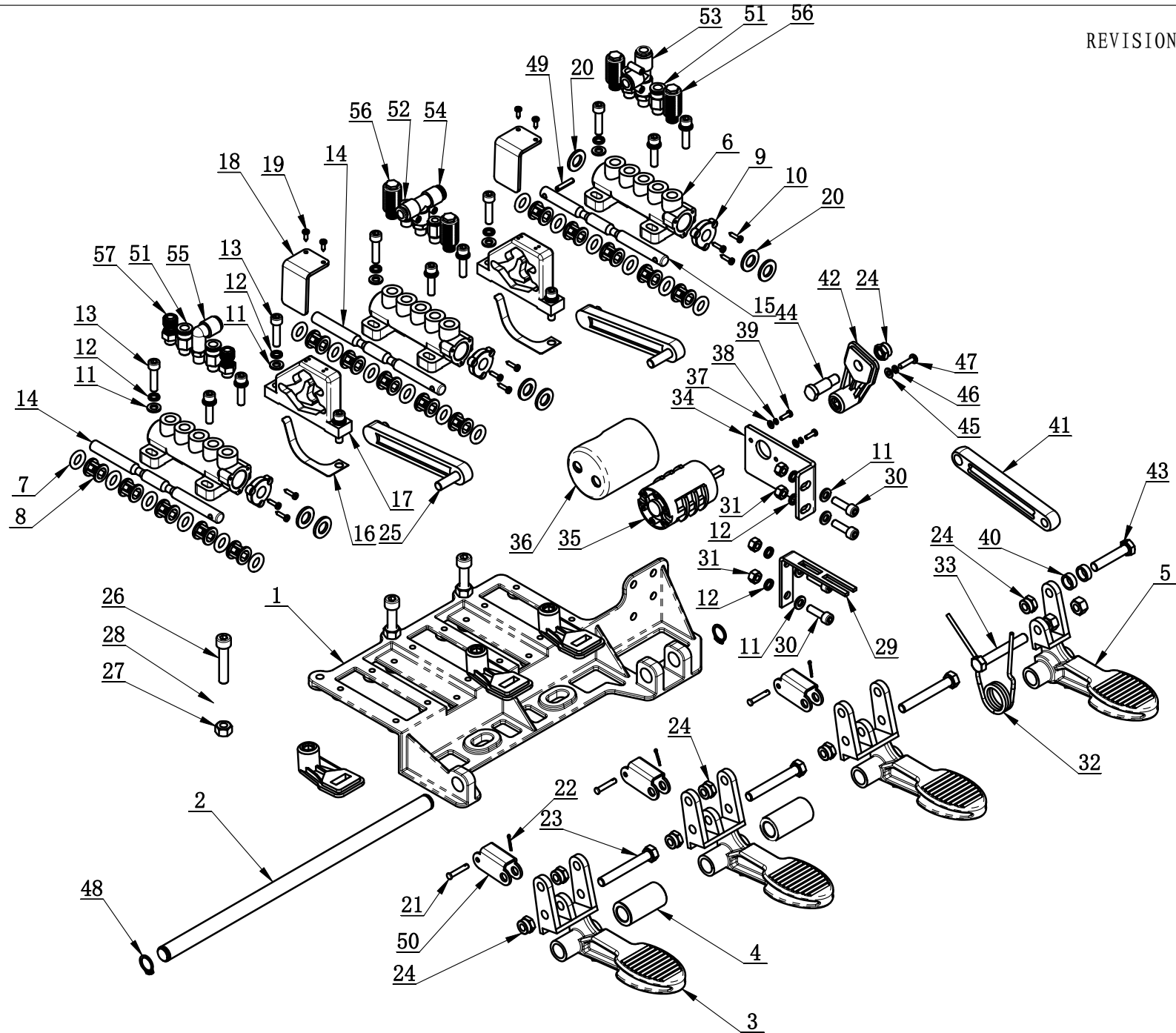

ITEM	PART. No	DESCRIPTION.	QT. Y
1	CT-D-6100001	PEDAL SUPPORT WELDING	1
2	CT-D-6100002	BOTTOM SHAFT	1
3	CT-D-5100003	PEDAL	3
4	CT-D-2100001	SPACER	2
5	CT-D-5100002	PEDAL	1
6	CT-D-1110001	VALVE BODY	3
7	CT-D-1110003	O-RING	18
8	CT-D-1110004	SPACER	15
9	CT-D-1110005	VALVE CAP	3
10	GB845-ST2.9×13 H C	CROSS PANHEAD TAPPING SCREW	9
11	GB95-6	FLAT WASHER	17
12	GB93-6	STANDARD SPRING WASHER	17
13	GB70.1-M6×25	INNER HEXA CYLINDRICAL SCREW	13
14	CT-D-2600003	VALVE ROD	2
15	CT-D-2600001	VALVE ROD	1
16	CT-D-2100004	SPRING PLATE	2
17	CT-D-1100009	CAM	2
18	CT-D-1100011	CAM BAFFLE PLATE	2
19	GB845-ST2.9×9.5 H C	CROSS PANHEAD TAPPING SCREW	4
20	GB95-10	FLAT WASHER	7
21	GB882-4×22	PIN SHAFT	3
22	GB91-1.6×10	SLOTTED PIN	3
23	GB5782-M8×60	HEXANGULAR BOLT	3
24	GB889.1-M8	1-TYPE PREVAILING TORQUE TYPE HEXAGON LOCK NUT	7
25	CT-D-1100008	CAM CONNECTING ROD	2
26	GB70.1-M8×40	INNER HEXA CYLINDRICAL SCREW	3
27	GB41-M8	HEXANGULAR NUT	5
28	CT-D-5100007	REVERSE LEVER	3
29	CT-D-2100010	TORSION SPRING BRACKET	1
30	GB70.1-M6×20	INNER HEXA CYLINDRICAL SCREW	4
31	GB41-M6	HEXANGULAR NUT	4
32	CT-D-2100002	TORSION SPRING	1
33	GB5782-M8×55	HEXANGULAR BOLT	1
34	CT-D-5100006	SWITCH SUPPORT	1
35	CT-D-1200004	SWITCH	1
36	CT-D-1200003	SWITCH COVER	1
37	GB95-3	FLAT WASHER	2
38	GB93-3	STANDARD SPRING WASHER	2
39	GB818-M3×10-H	CROSS PANHEAD SCREW	2
40	CT-D-2100005	SPACER	2

ITEM	PART. No	DESCRIPTION.	QT. Y
41	CT-D-2100011	CONNECTION ROD	1
42	CT-D-1200002	REVERSE LEVER	1
43	GB5781-M8×40	HEXANGULAR BOLT	1
44	CT-D-2100012	ROTATION SHAFT	1
45	GB95-4	FLAT WASHER	1
46	GB93-4	STANDARD SPRING WASHER	1
47	GB818-M4×16-H	CROSS PANHEAD SCREW	1
48	GB894. 1-14	SHAFT ELATIC BIG RETAINING RING A-TYPE	2
49	GB879. 1-4×20	ELASTIC CYLINDRICAL PIN, HEAVY	1
50	CT-D-5100005	CONNECT ASSEMBLY	3
51	FPC 8-01	MALE STRAIGHT	4
52	FPC 6-01	MALE STRAIGHT	2
53	FPD 8-01	MALE RUN TEE	1
54	FPB 8-01	MALE BRANCH TEE	1
55	FPL 8-01	INSERT ELBOW Φ8, R1/8	1
56	FSK 01	PLASTIC PARTICLE SILENCER	4
57	FJSR 01	BRASS REGULATOR SILENCER	2

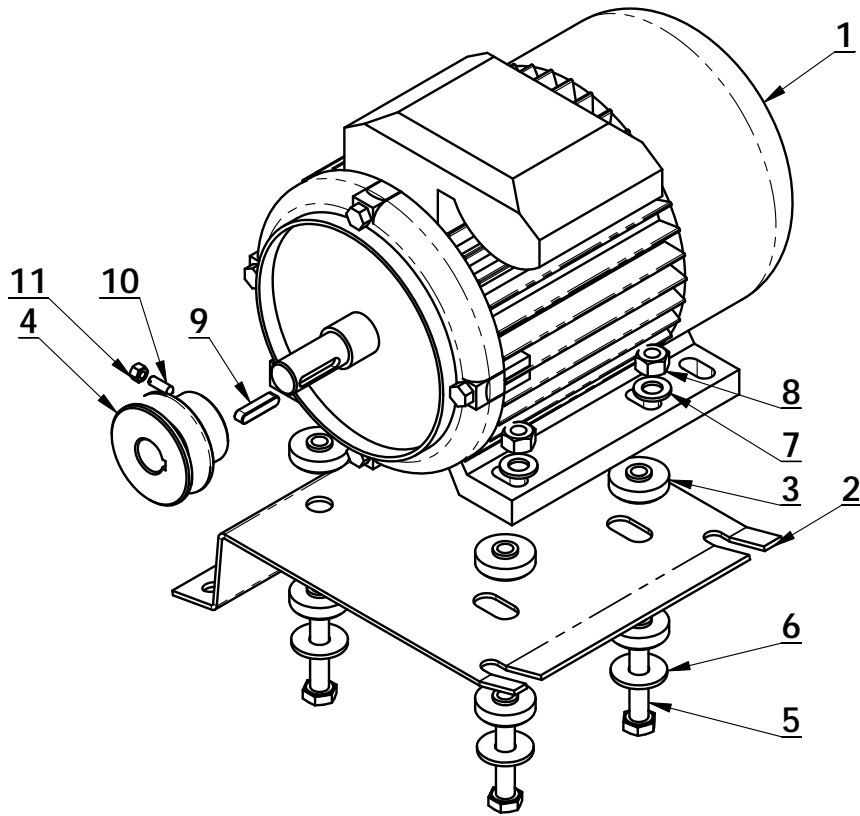

ITEM	PART. No	DESCRIPTION.	QT. Y
1	CT-DJ-0018112	MOTOR	1
2	CT-DJ-0000001	MOTOR SUPPORT	1
3	CT-DJ-0000002	RUBBER WASHER	8
4	CT-DJ-0000003	MOTOR BELT PULLEY	1
5	GB5781-M10×50	HEXANGULAR BOLT	4
6	GB96. 2-10	LARGE WASHER C GRADE	4
7	GB95-10	FLAT WASHER	4
8	GB41-M10	HEXANGULAR NUT	4
9	GB1096-6×6×28	COMMON FLAT KEY	1
10	GB71-M5×16	SLOTTED CONIC HEAD SET SCREW	1
11	GB41-M5	HEXANGULAR NUT	1

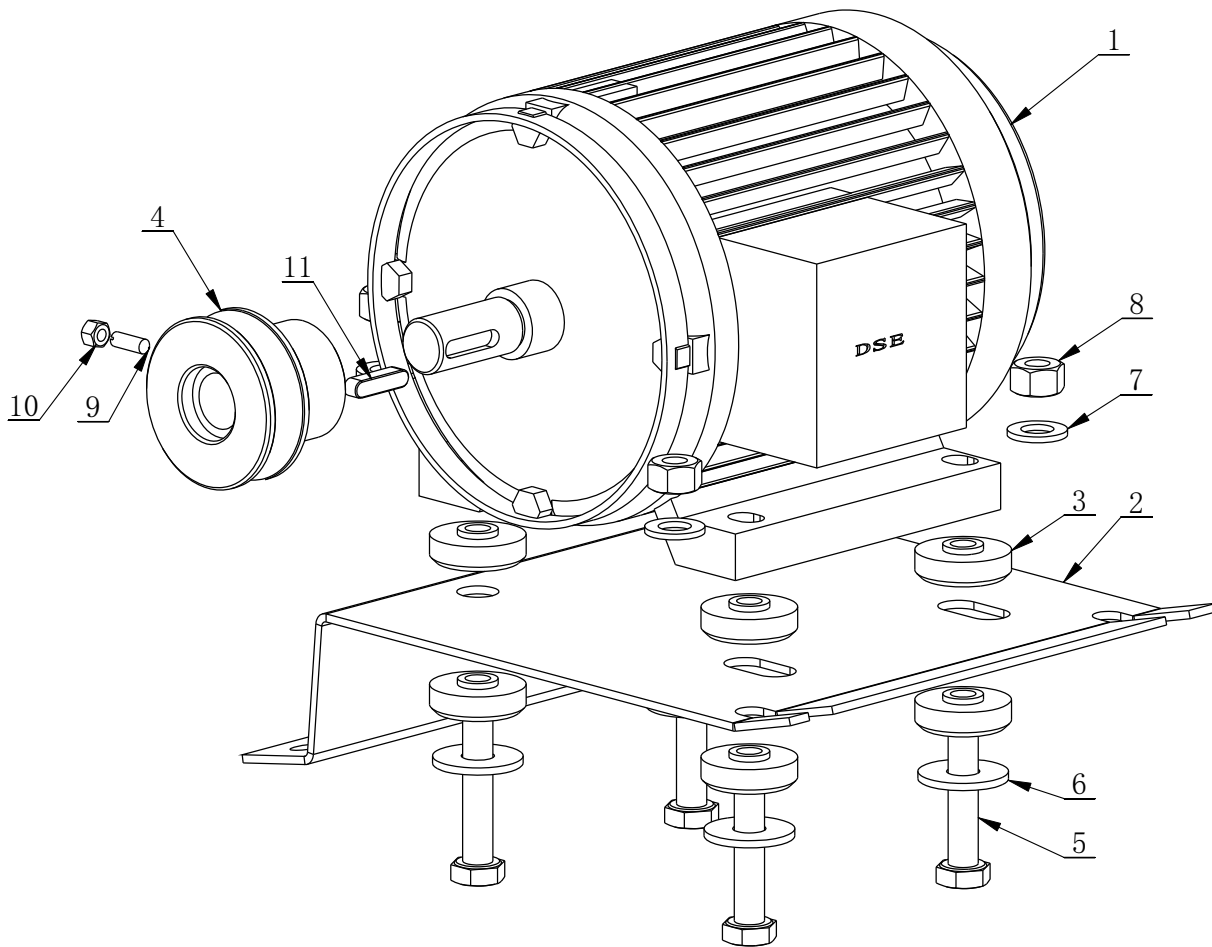

ITEM	PART. No	DESCRIPTION.	QT. Y
1	CT-DJ-0034122	MOTOR (0.75KW 380V 50Hz 3P)	1
2	CT-DJ-0000001	MOTOR SUPPORT	1
3	CT-DJ-0000002	RUBBER WASHER 220V MOTOR BELT PULLEY (Φ 58X40)	8
4	CT-DJ-0000003		1
5	GB5781-M10 \times 50	HEXANGULAR BOLT	4
6	GB96.2-10	LARGE WASHER C GRADE	4
7	GB95-10	FLAT WASHER	4
8	GB41-M10	HEXANGULAR NUT	4
9	GB71-M5 \times 16	SLOTTED CONIC HEAD SET SCREW	1
10	GB41-M5	HEXANGULAR NUT	1
11	GB1096-6 \times 6 \times 25	COMMON FLAT KEY	1

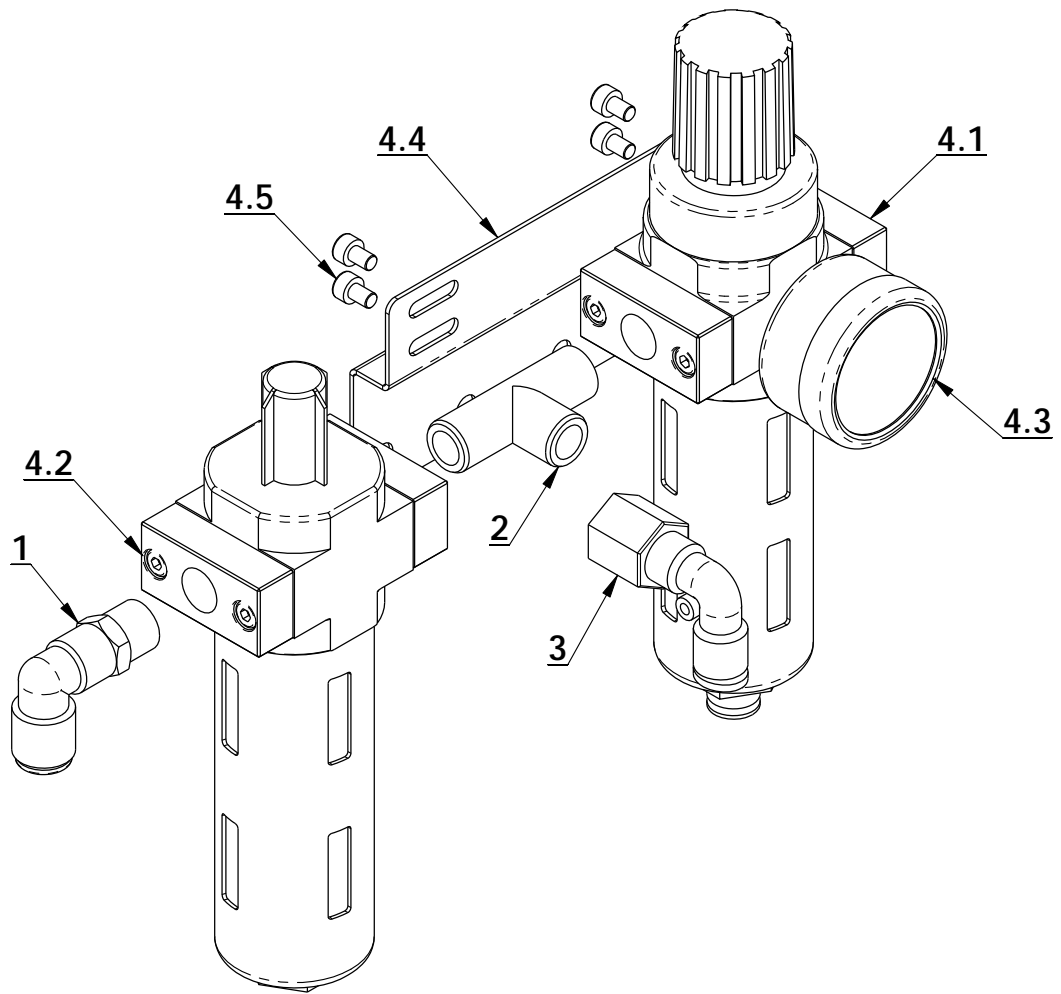

ITEM	PART. No	DESCRIPTION.	QT. Y
1	FPL 8-02	INSERT ELBOW $\Phi 8$, R1/4	1
2	PEH 02-02	FAMALE UNION TEE	1
3	FPLF8-02	INSERT ELBOW $\Phi 8$, R1/4	1
4	CT-F-2000100	AIR REGULATOR	1
4.1	CT-F-2000010	PRESSURE ADJUST VALVE AND WATER CUP	1
4.2	CT-F-2000020	OIL CUP	1
4.3	CT-F-2000003	PRESSURE GAUGE	1
4.4	CT-F-2000040	AIR REGULATOR BRACKET	1
4.5	GB/T70.1- M4x6	INNER HEXA CYLINDRICAL SCREW	4

CT-J-4100000

REDUCER CT-J-4100000

REVISION 15A-01

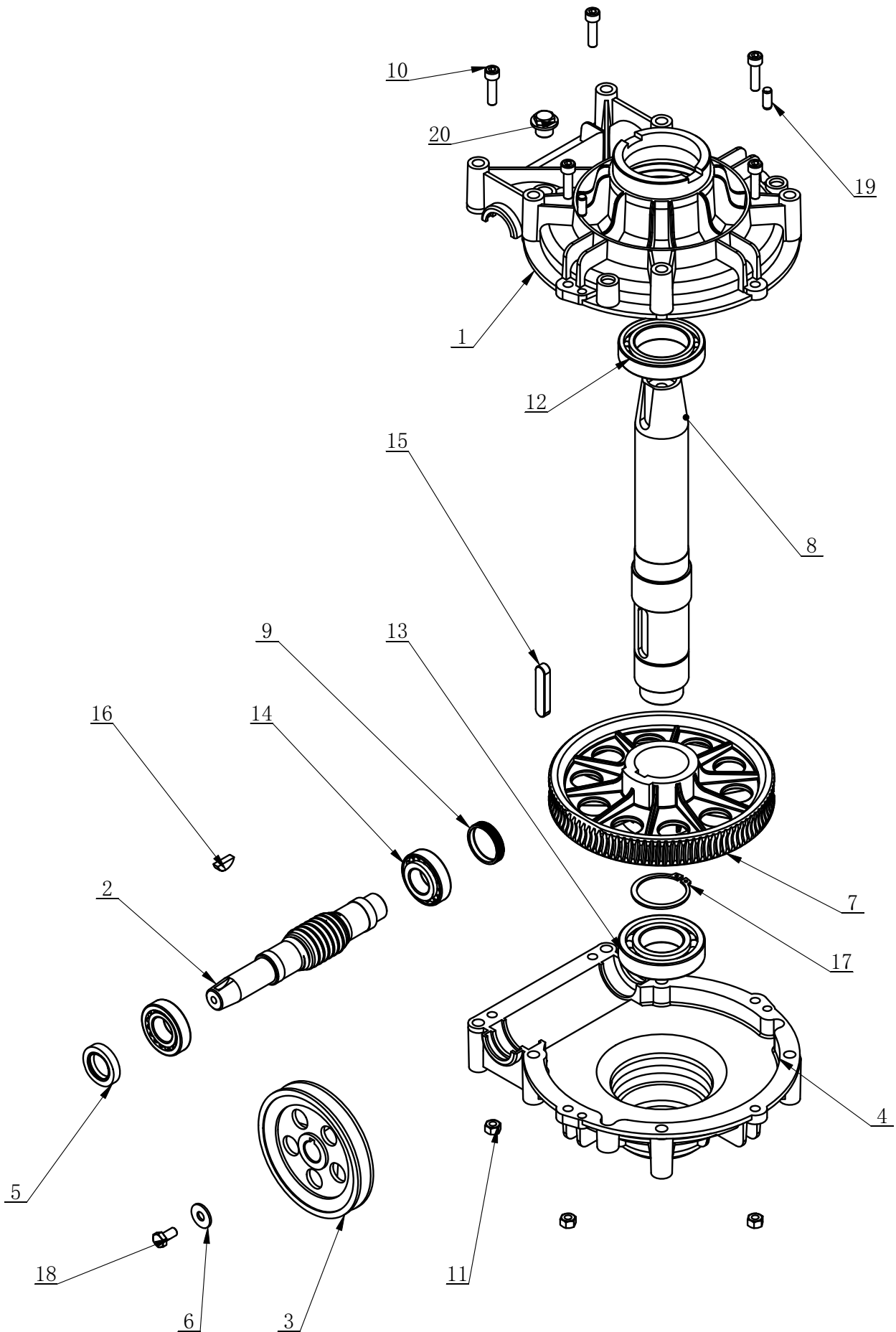

ITEM	PART. NO	DESCRIPTION.	QT. Y
1	CT-J-0000006	GEARBOX TOP	1
2	CT-J-0000004	WORM ROD	1
3	CT-J-0000008	BELT PULLEY	1
4	CT-J-0000005	GEARBOX TOP	1
5	FB25-40 GB13871.92	SEALED RING	1
6	GB96.2-8	LARGE WASHER C GRADE	1
7	CT-J-0000003	WORM	1
8	CT-J-0000002	WORM SHAFT	1
9	CT-J-0100000	CAP	1
10	GB70.1-M8×30	INNER HEXA CYLINDRICAL SCREW	5
11	GB41-M8	HEXANGULAR NUT	5
12	GB276-6010	DEEP GROOVE BALL BEARINGS	1
13	GB276-6208	DEEP GROOVE BALL BEARINGS	1
14	GB297-30205	CYLINDRICAL BALL BEARING	2
15	GB1096-12×8×56	COMMON FLAT KEY	1
16	GB1099.1-6×9×22	COMMON SEMI-CIRCULAR KEY	1
17	GB894.1-50	SHAFT ELATIC BIG RETAINING RING A-TYPE	1
18	GB5781-M8×16	HEXANGULAR BOLT	1
19	GB119.1-8×20	CYLINDRICAL PIN	2
20	TC-10-1400013	BOLT	1

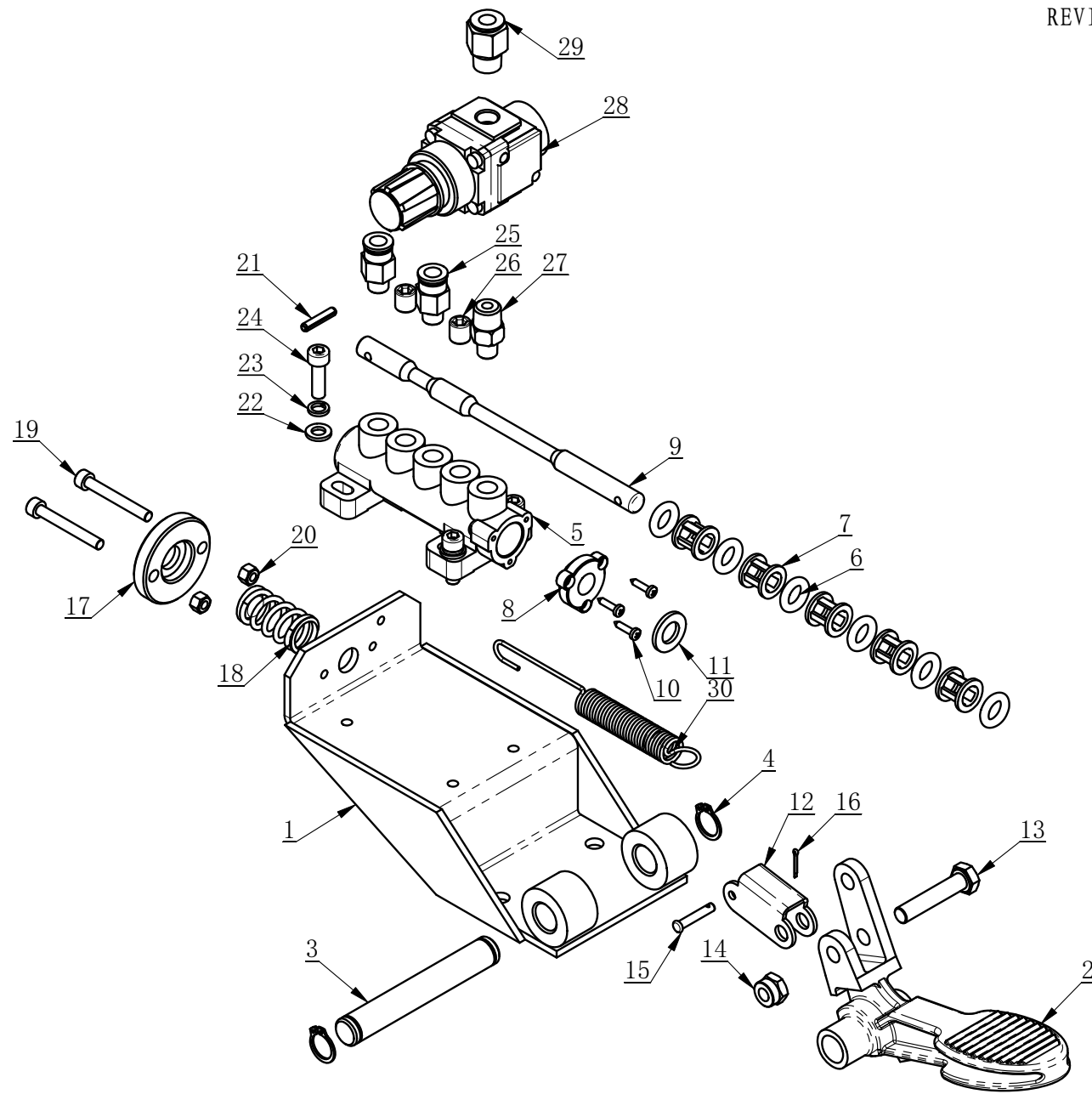

ITEM	PART. No	DESCRIPTION.	QT. Y
1	CT-K-1A10000	PEDAL SUPPORT WELDING	1
2	CT-D-5100002	PEDAL	1
3	CT-K-1100006	SHAFT	1
4	GB894. 1-14	SHAFT ELATIC BIG RETAINING RING A-TYPE	2
5	CT-D-1110001	VALVE BODY	1
6	CT-D-1110003	O-RING	6
7	CT-D-1110004	SPACER	5
8	CT-D-1110005	VALVE CAP	1
9	CT-K-1A00002	VALVE ROD	1
10	GB845-ST2. 9×13 H C	CROSS PANHEAD TAPPING SCREW	3
11	GB95-10	FLAT WASHER	1
12	CT-D-5100005	CATENATION	1
13	GB5781-M8×40	HEXANGULAR BOLT	1
14	GB889. 1-M8	1-TYPE PREVAILING TORQUE TYPE HEXAGON LOCK NUT	1
15	GB882-4×22	PIN SHAFT	1
16	GB91-1. 6×10	SLOTTED PIN	1
17	CT-K-1100002	MOVABLE PLATE	1
18	CT-K-1100003	SPRING	1
19	GB70. 1-M5×40	INNER HEXA CYLINDRICAL SCREW	2
20	GB41-M5	HEXANGULAR NUT	2
21	GB879. 1-4×20	ELASTIC CYLINDRICAL PIN, HEAVY	1
22	GB95-6	FLAT WASHER	3
23	GB93-6	STANDARD SPRING WASHER	3
24	GB70. 1-M6×20	INNER HEXA CYLINDRICAL SCREW	3
25	FPC 8-01	MALE STRAIGHT	2
26	JB / ZQ4447-1997-G1 / 8×10	SCREWS PLUG R1/8" x10	2
27	CT-K-1100007	FITTING	1
28	AR20-01	PRESSURE REDUCING VALVE	1
29	FPC 8-02	MALE STRAIGHT	1
30	CT-K-1A00001	SPRING	1

QUICK EXHAUST VALVE ASSEMBLY CT-K-2200000

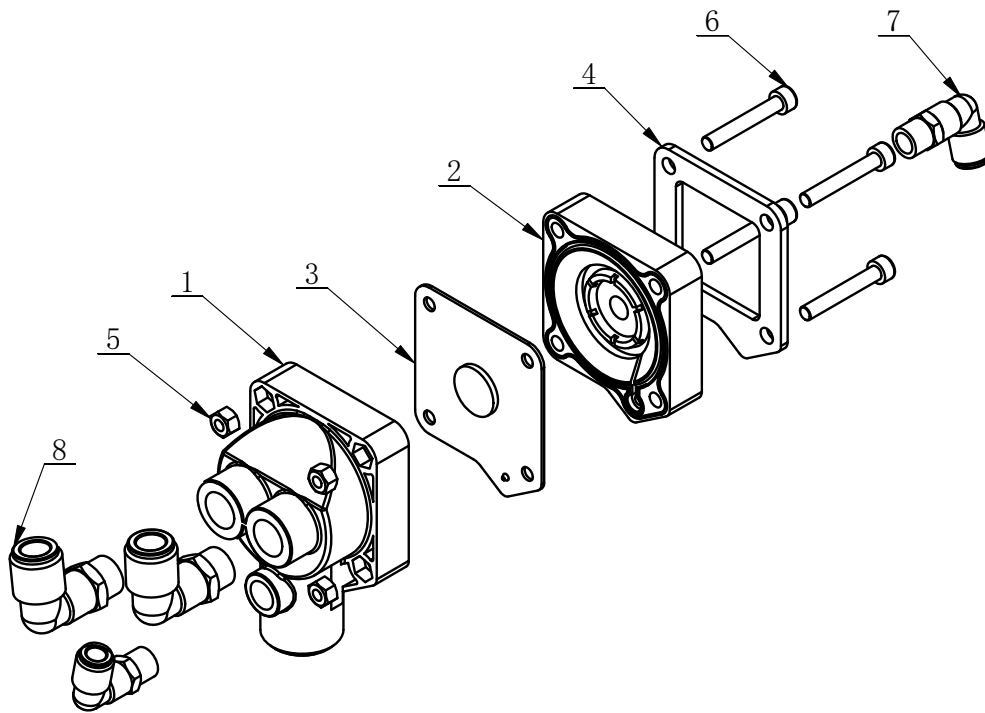

ITEM	PART. No	DESCRIPTION.	QT. Y
1	CT-K-2200002	BOTTOM COVER	1
2	CT-K-2200001	UPPER COVER	1
3	CT-K-2210000	PANEL	1
4	CT-K-2200003	WASHER	1
5	GB41-M6	HEXANGULAR NUT	4
6	GB70. 1-M6×40	INNER HEXA CYLINDRICAL SCREW	4
7	FPL 8-02	INSERT ELBOW Φ8, R1/4	2
8	FPL 12-03	INSERT ELBOW Φ12 R3/8"	2

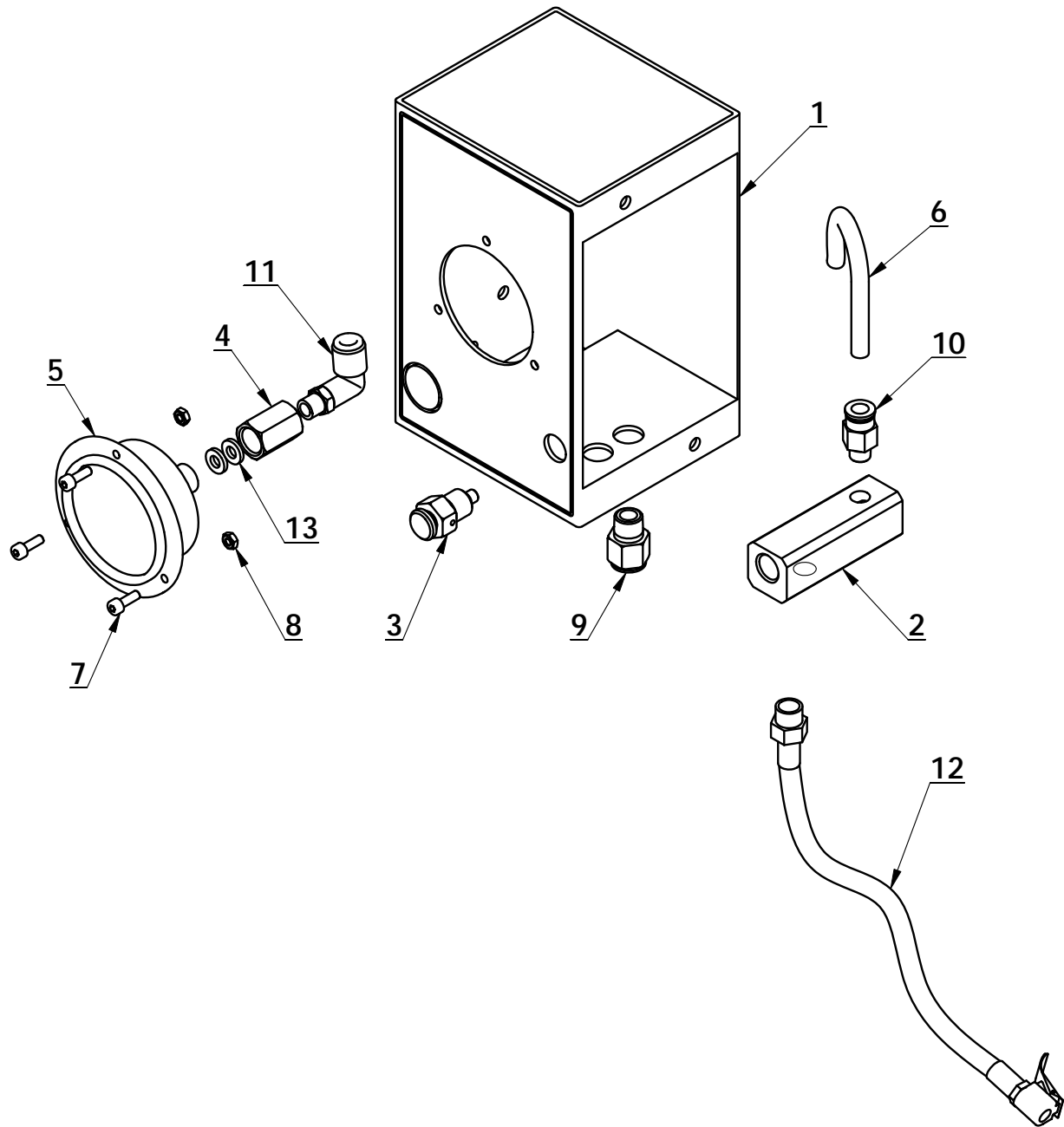

ITEM	PART. No	DESCRIPTION.	QT. Y
1	CT-K-3100001	PRESSURE GAUGE COVER	1
2	CT-K-3120000	AIR DISTRIBUTING VALVE	1
3	CT-K-3110000	EXHAUST VALVE ASSEMBLY	1
4	CT-K-3100002	CONNECT NUT	1
5	CT-K-3100004	PRESSURE GAUGE	1
6	PU-0800180-Y	PU HOSE $\Phi 8 \times 5$	1
7	GB70. 1-M4 \times 12	INNER HEXA CYLINDRICAL SCREW	3
8	GB6170-M4	HEXANGULAR NUT 1-TYPE	3
9	FPC 8-02	MALE STRAIGHT	1
10	FPC 8-01	MALE STRAIGHT	1
11	FPL 8-01	INSERT ELBOW $\Phi 8, R1/8$	1
12	CT-K-3100003	INFLATING HOSE	1
13	TC-10-1620003	AIR REGULATOR WASHER	2

CT-LS-9200000

REVISION 15A-01

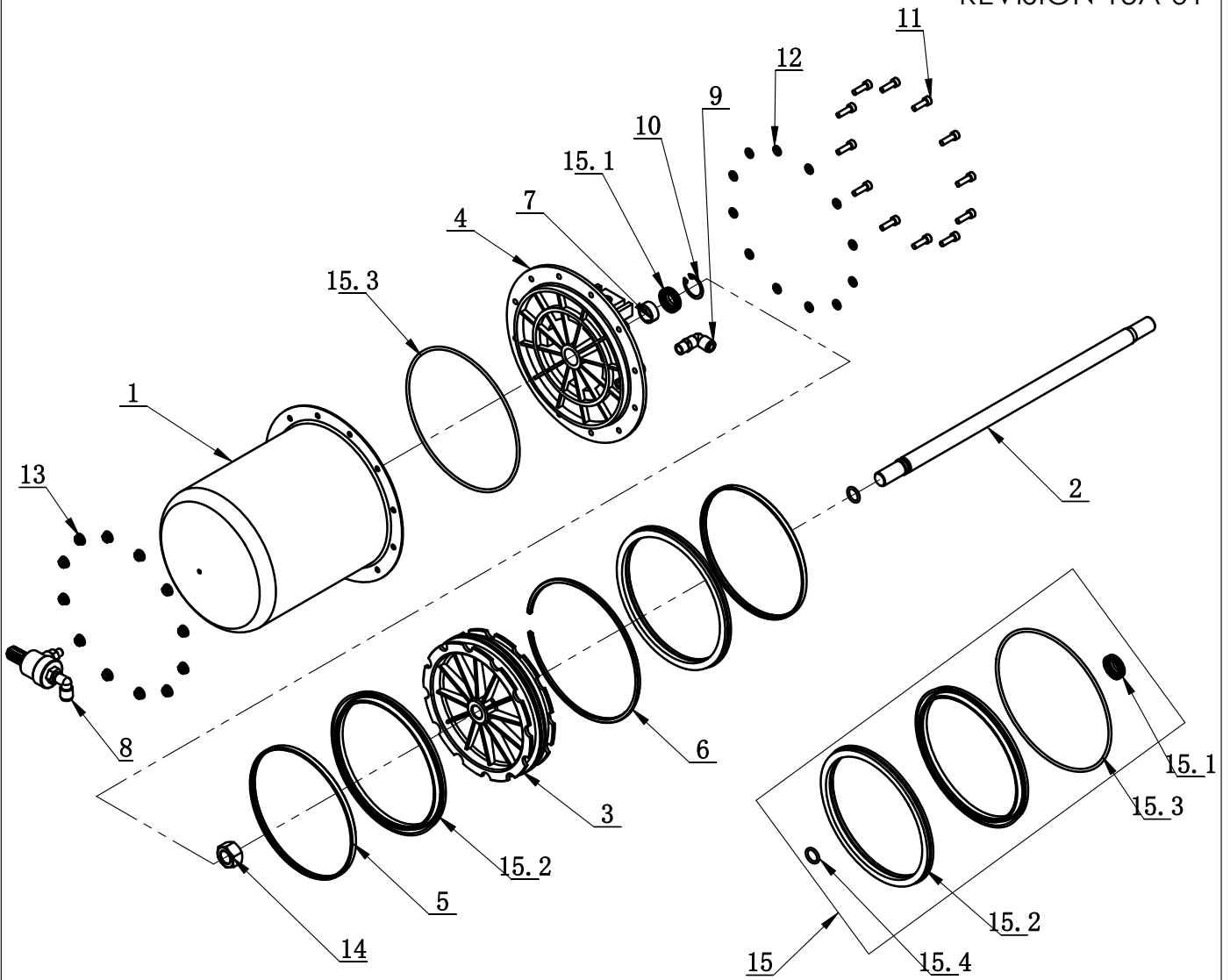

ITEM	PART. No	DESCRIPTION.	QT. Y
1	CT-LS-1100002	CYLINDER BODY	1
2	CT-LS-9100001	CYLINDER PISTON ROD	1
3	CT-LS-1100003	PISTON	1
4	CT-LS-1100004	CYLINDER COVER	1
5	CT-LS-1100006	CLAMP RING	2
6	CT-LS-1100007	PISTON SUPPORT RING	1
7	CT-LS-1100008	GUIDER SPACER	1
8	CT-LS-1320000	QUICK DEFLATE VALVE ON BODY	1
9	FPL 8-02	INSERT ELBOW $\Phi 8$, R1/4	1
10	GB893. 2-30	ELASTIC RETAINING RING B-TYPE	1
11	GB70. 1-M6 \times 20	INNER HEXA CYLINDRICAL SCREW	12
12	GB95-6	FLAT WASHER	12
13	GB6177. 1-M6	HEXA FLANGE NUT	12
14	GB6171- M18 \times 1. 5	NUT THIN TOOTH	1
15	CT-LS-1110000	CYCLINDER SEALING PARTS ASSEMBLY	1
15. 1	CT-Y-0160007	SEAL-ROD, CYLNDR	1
15. 2	CT-LS-1100009	Y-RING	2
15. 3	GB3452. 1-185 \times 3. 55-G	O-RING G TYPE	1
15. 4	GB3452. 1-15. 5 \times 2. 65-G	HYDRAULIC-PNEUMATIC RUBBER O-RING G TYPE	1

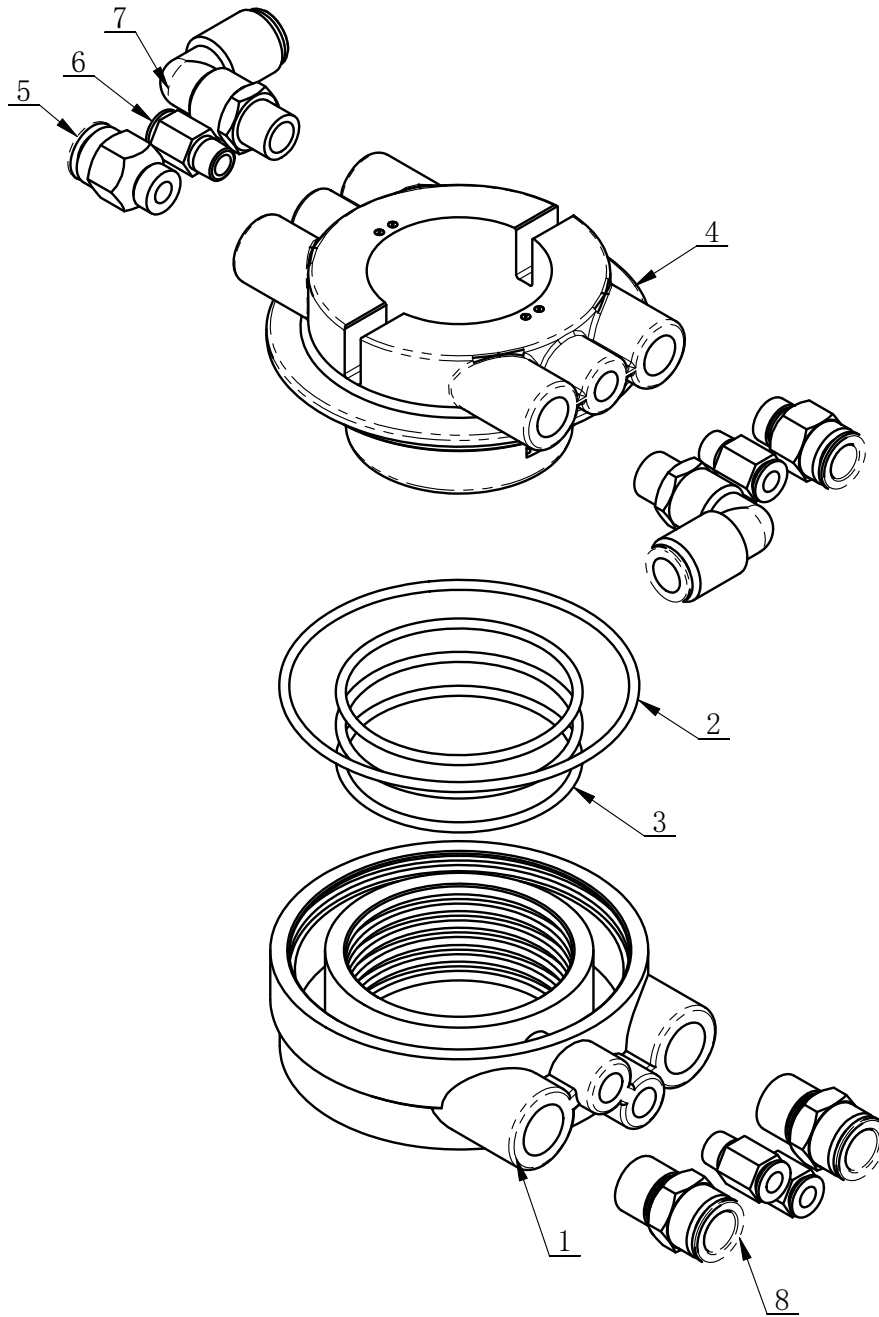

ITEM	PART. No	DESCRIPTION.	QT. Y
1	CT-Q-A100001	AIR GUIDE EXTERNAL BUSHING	1
2	GB3452. 1-90×2. 65-G	O-RING 90X2. 65	1
3	GB3452. 1-60×2. 65-G	HYDRAULIC-PNEUMATIC RUBBER O-RING G TYPE	3
4	CT-Q-A110000	AIR GUIDE ROTATION BUSHING	1
5	FPC 10-02	MALE STRAIGHT	2
6	FPC 6-01	MALE STRAIGHT	4
7	FPL 10-02	MALE ELBOW	2
8	FPC 12-03	MALE STRAIGHT	2

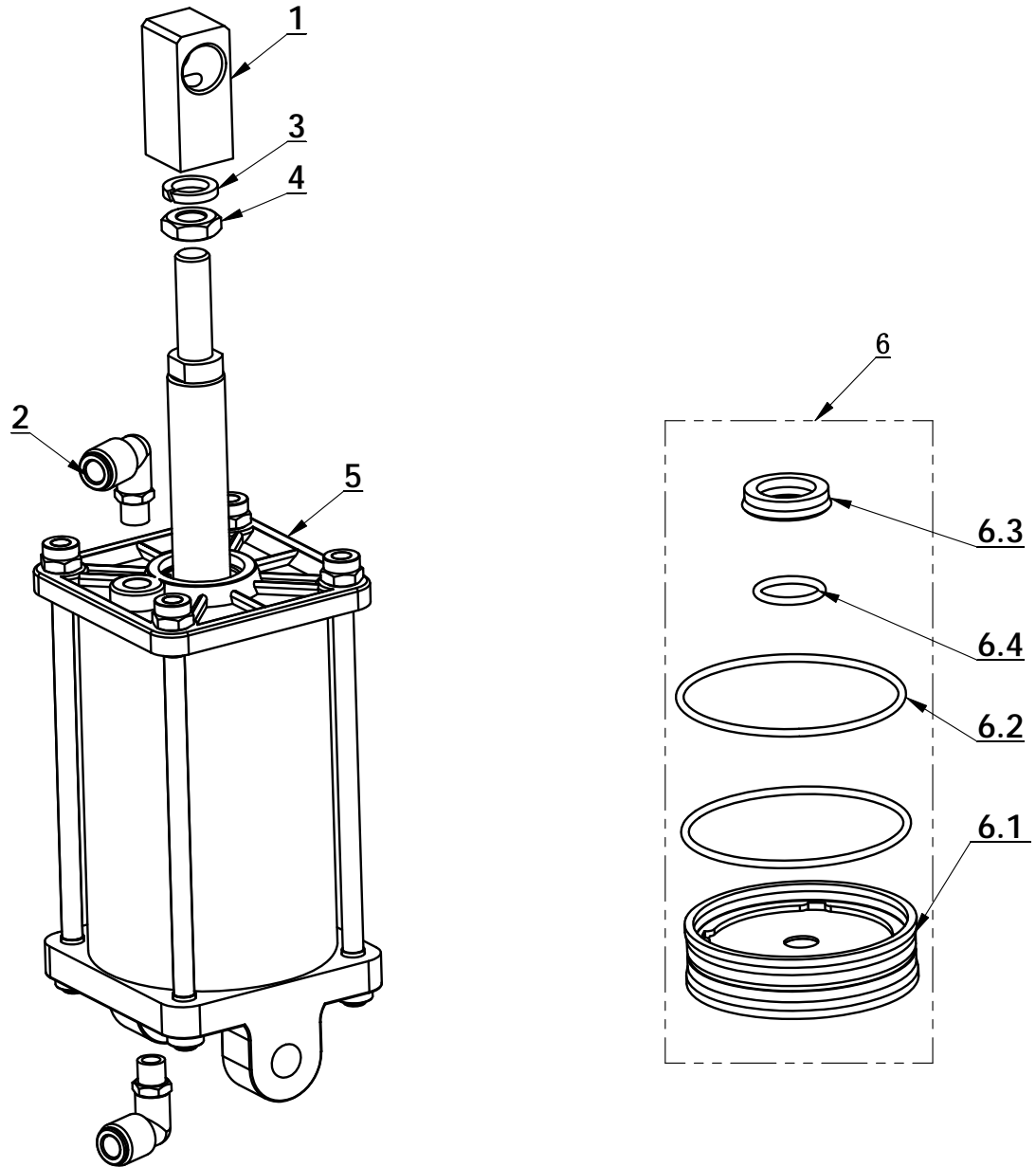

序号	编码	中文名称	数量
1	CT-XD-1000004	联轴结	1
2	FPL 8-01	内插弯头 $\Phi 8$,R1/8	2
3	GB93-12	标准型弹簧垫圈 12	1
4	GB/T6172.1-M12	六角薄螺母 M12	1
5	CT-XD-3100000	定出缸D80x84	1
6	CT-XD-2100000	密封圈总成	1
6.1	CT-Y-4120006	活塞80	1
6.2	GB3452.1-75×2.65	通用O形圈 G型 75×2.65-G	2
6.3	CT-Y-0160007	防尘密封圈 (骨架) 30x20x7	1
6.4	GB3452.1-20×2.65	通用O形圈 G型 20×2.65-G	1

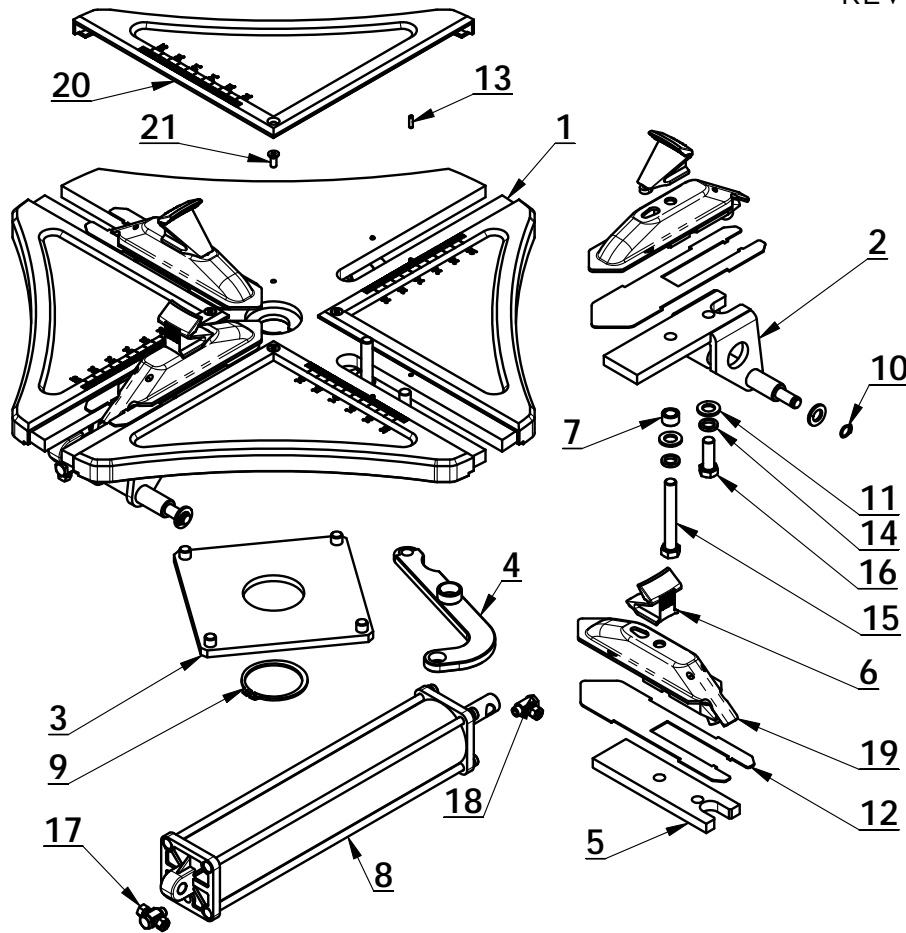

ITEM	PART. No	DESCRIPTION.	QT. Y
1	CT-Y-1A10000	TURN TALBE	1
2	CT-Y-1140000	BRACKET-CYLINDER	2
3	CT-Y-0150000	SQUARE TURNTABLE	1
4	CT-Y-1150000	CONNECTION PLATE	4
5	CT-Y-2100001	BOTTOM CHUTE PRESS PLATE	2
6	CT-Y-0100002	CLAMP	4
7	CT-Y-0100003	SPACER	4
8	CT-Y-1430000	CYLINDER ASSEMBLY	2
9	GB894. 1-65	SHAFT ELATIC BIG RETAINING RING A-TYPE	1
10	GB894. 1-12	SHAFT ELATIC BIG RETAINING RING A-TYPE	4
11	GB95-12	FLAT WASHER	12
12	CT-Y-1400001	WEAR-RESISTANCE SPACER	4
13	GB879. 1-4×14	ELASTIC CYLINDRICAL PIN HEAVY	8
14	GB93-12	STANDARD SPRING WASHER	8
15	GB5782-M12×85	HEXANGULAR BOLT	4
16	GB5783-M12×35	HEXANGULAR BOLT	4
17	CT-Y-0100009	HINGE ELBOW Φ6	2
18	CT-Y-0100007	HINGE ELBOW Φ6 R1/8"	2
19	CT-Y-0320000	SLIDE COVER	4
20	CT-Y-1A00001	PROTECTIVE COVER	4
21	GB70. 3-M6×16	INNER COUNTER SUNK SCREW	4

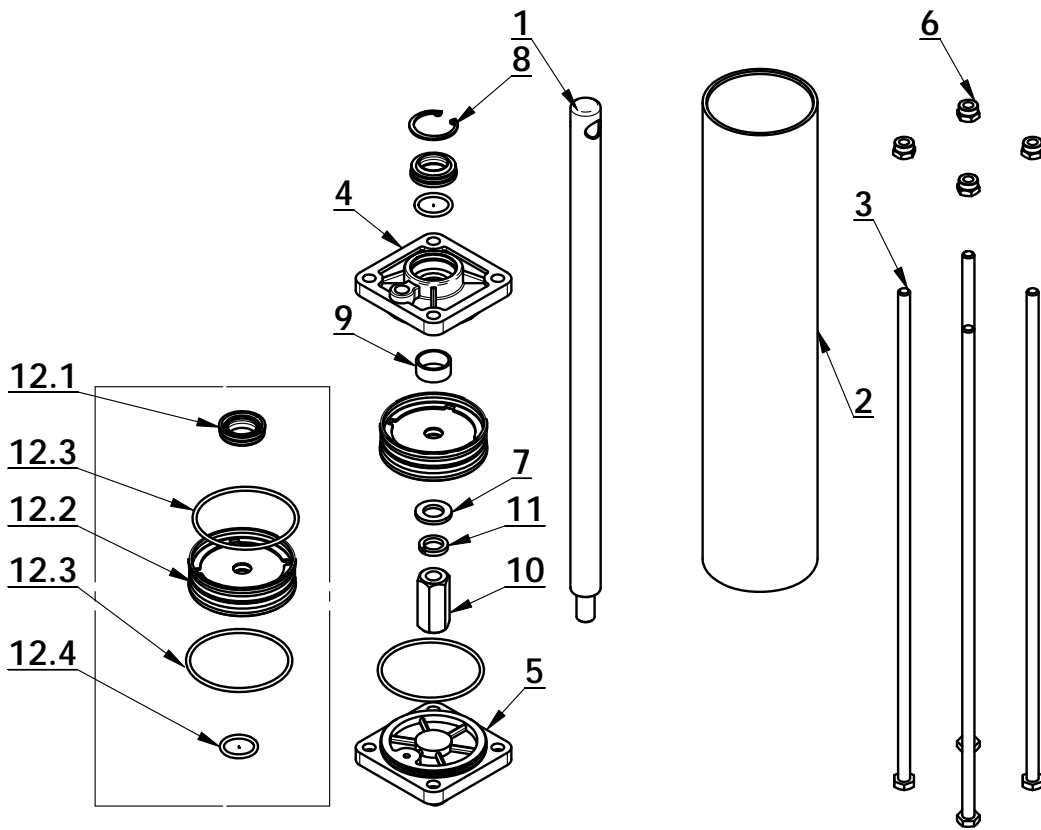

ITEM	PART. No	DESCRIPTION.	QT. Y
1	CT-Y-1120001	SHAFT-CYLNDR	1
2	CT-Y-1120002	SLEEVE-CYLNDR 70	1
3	CT-Y-1120003	BOLT	4
4	CT-Y-0160002	FRONT COVER	1
5	CT-Y-0160003	REAR COVER	1
6	GB889. 1-M8	1-TYPE PREVAILING TORQUE TYPE HEXAGON LOCK NUT	4
7	GB95-12	FLAT WASHER	1
8	GB893. 1-30	ELASTIC RETAINING RING A-TYPE	1
9	JH1 2010	BEARING-SLIDE	1
10	CT-Y-1430001	AN ELONGATED NUT	1
11	GB93-12	STANDARD SPRING WASHER	1
12	CT-Y-1121000	CYLINDER SEALING PARTS ASSEMBLY	1
12. 1	CT-Y-0160007	SEAL-ROD, CYLNDR	1
12. 2	CT-Y-0161000	PISTON-W/WSHR, ASSY	1
12. 3	GB3452. 1-65×2. 65	HYDRAULIC-PNEUMATIC RUBBER O-RING G TYPE	2
12. 4	GB3452. 1-20×2. 65	HYDRAULIC-PNEUMATIC RUBBER O-RING G TYPE	1

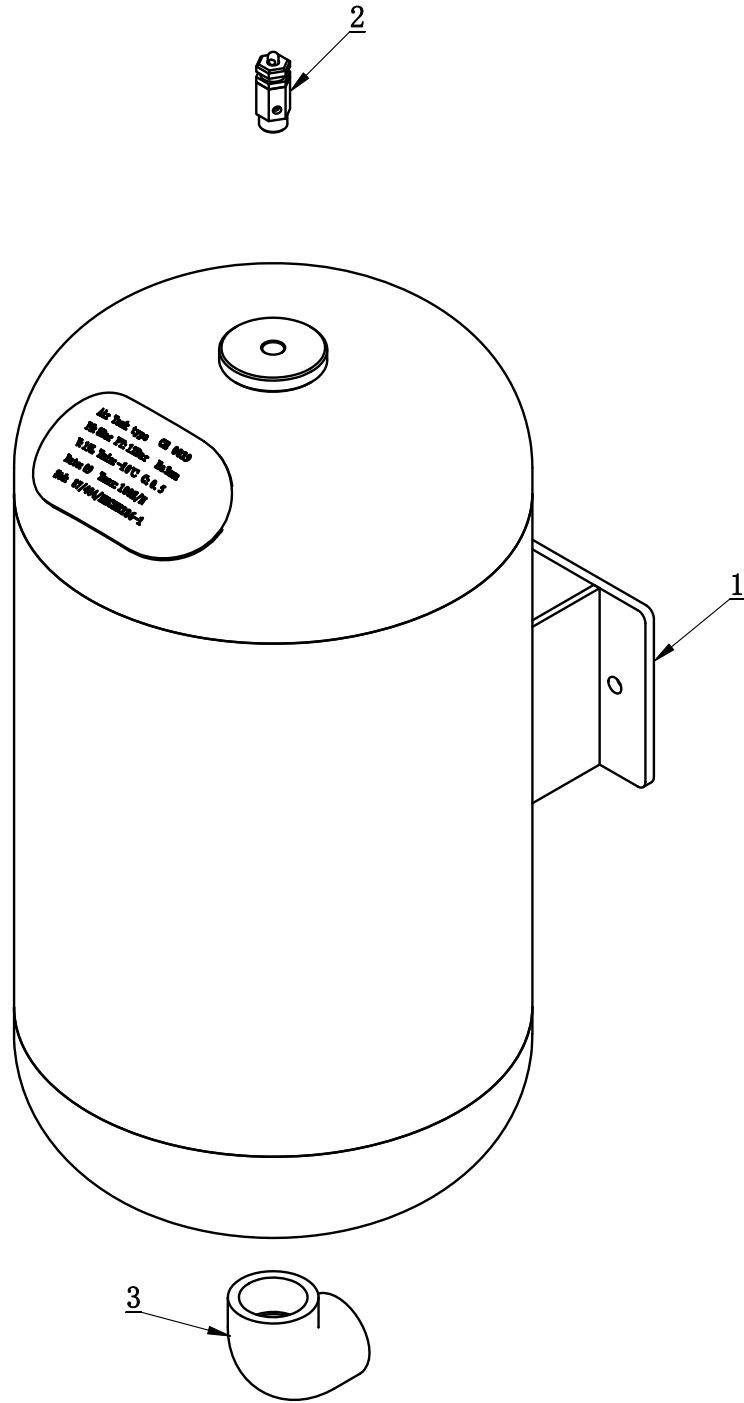

ITEM	PART. No	DESCRIPTION.	QT. Y
1	CT-K-4110000	AIR TANK	1
2	CT-K-4100001	SAFE VALVE	1
3	CT-K-4100002	ELBOW_90,GT"	1

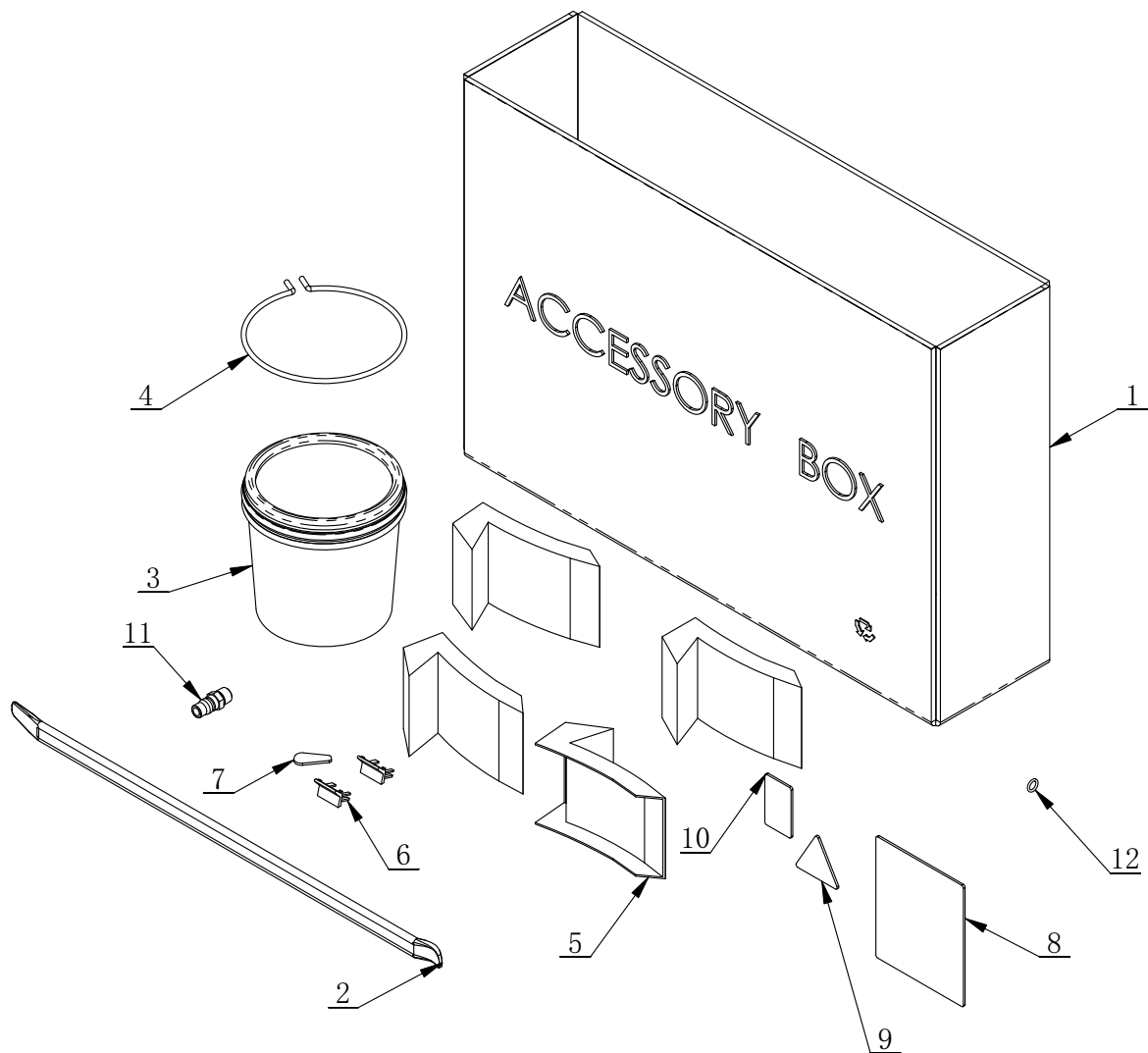

ITEM	PART. No	DESCRIPTION.	QT. Y
1	C-54-8000002	ACCESSORY BOX	1
2	C-54-8000003	20INCH CROWBAR	1
3	C-54-8100000	GREASE CONTAINER	1
4	C-54-8000004	BRACKET	1
5	C-54-8000005	CLAMP PROTECTION COVER	4
6	C-54-8000006	SHEATH	2
7	C-54-8000007	PLASTIC COVER	1
8	C-54-8000008	USER MANUAL	1
9	C-54-8000009	PASS CARD	1
10	C-54-8000010	GUARANTEE	1
11	C-54-8000011	AIR SUPPLY CONNECTOR	1
12	GB / T 3452.1-2005 8x2.65	HYDRAULIC-PNEUMATIC RUBBER O-RING G TYPE	1